

Reflector Clamp

Holes:
 A = 0.250" dia.*
 B = 8-32 Tap

* Drill 1/8" pilot holes first and later drill 1/4" through element clamps and boom aligned together

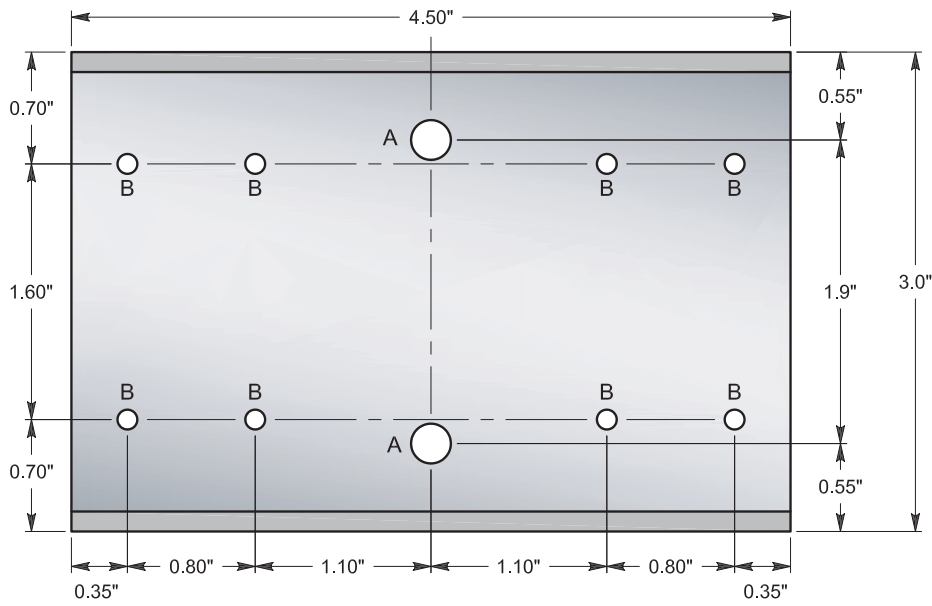

Driven Element Clamp

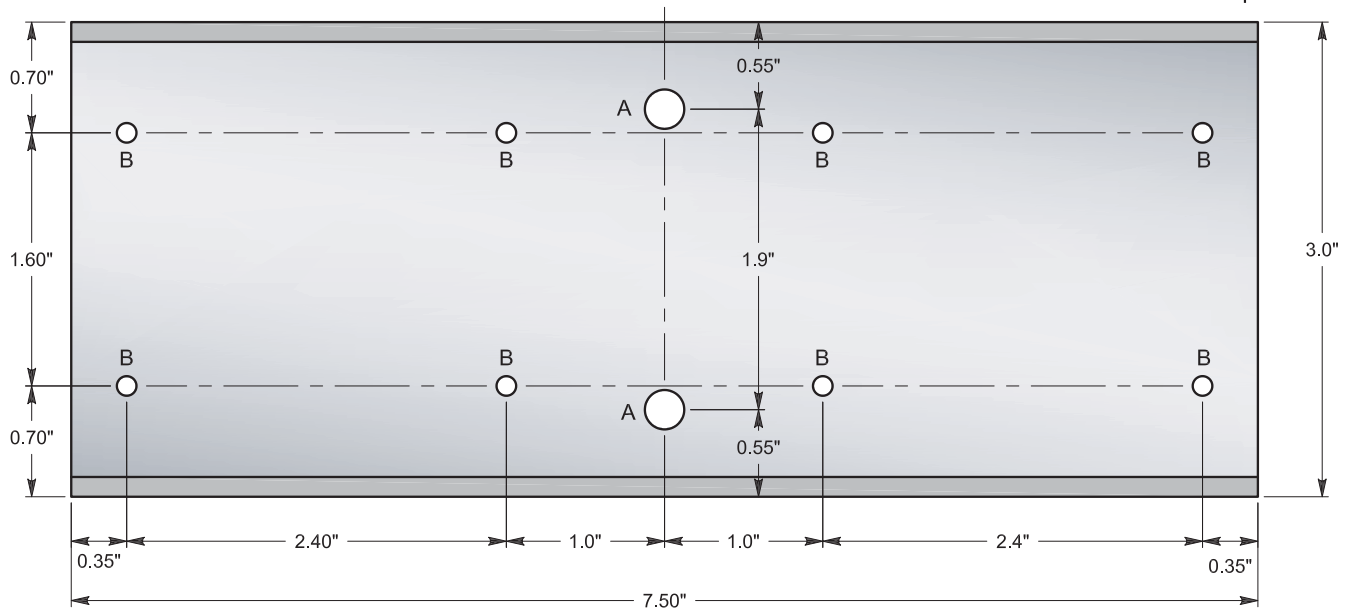

Element support clamps.

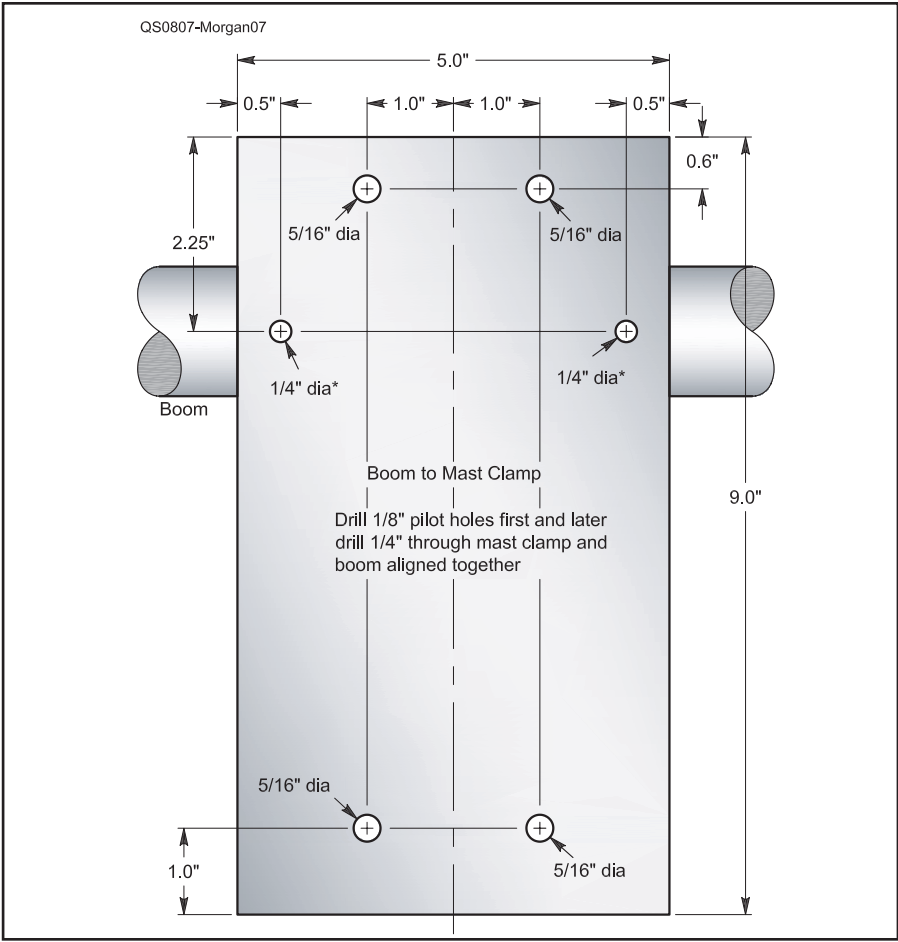

Detail of mast to boom plate.